

**General Description**

Series D1FV proportional pressure reducing valves are available with and without onboard electronics (OBE).

**D1FV OBE**

The digital onboard electronics is situated in a robust metal housing, which allows the usage under rough environmental conditions.

The nominal values are factory set. The cable for connection to a serial RS-232 interface is available as accessory.

**D1FV for External Electronics**

The parameters can be saved, changed and duplicated in combination with the digital power amplifier PWD00A-400. The value parameters can be edited with the common ProPxD software for both versions.

The D1FV values control the pressure in the A- or B-ports using the barometric feedback principle.

**Features**

- Barometric feedback.
- 3 command options for D1FV OBE:  $\pm 10V$ , 4...20mA,  $\pm 20mA$ .
- High repeatability from valve to valve.
- Low hysteresis.
- Manual override.
- Pressure ranges 25 Bar (363 PSI) and 45 Bar (653 PSI).

**B**



D1FV



D1FV OBE

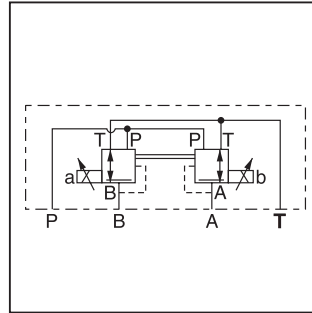

Function C

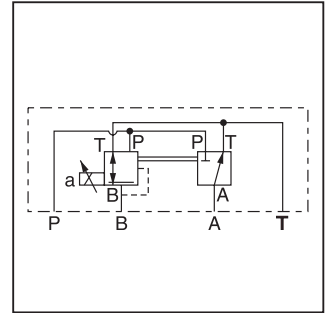

Function E

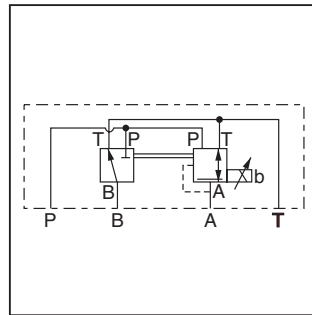

Function K

**D1FV\*3 OBE**

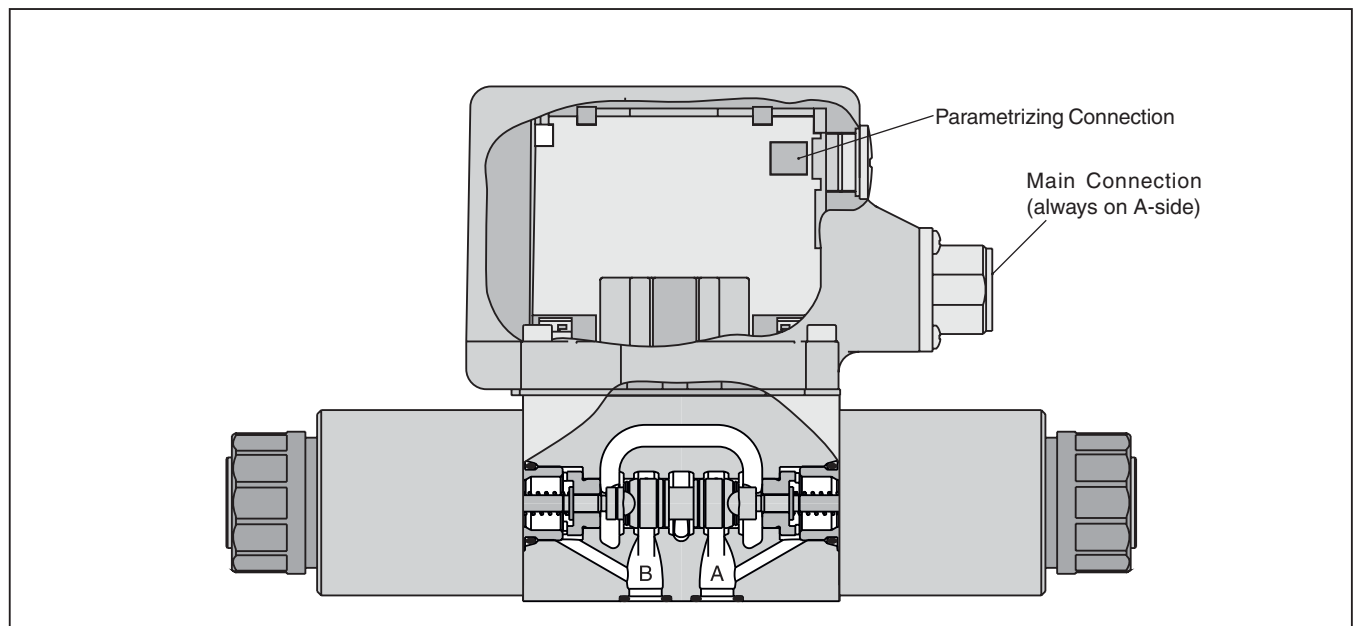

**D1FV Offboard Electronics**

<div style="border: 1px solid black; padding: 2px; width: 30px; margin: 0 auto;">D</div> <p style="font-size: 8px;">Proportional Pressure Reducing Valve</p>	<div style="border: 1px solid black; padding: 2px; width: 30px; margin: 0 auto;">1</div> <p style="font-size: 8px;">Size DIN NG6 CETOP 3 NFPA D03</p>	<div style="border: 1px solid black; padding: 2px; width: 30px; margin: 0 auto;">F</div> <p style="font-size: 8px;">Proportional Control</p>	<div style="border: 1px solid black; padding: 2px; width: 30px; margin: 0 auto;">V</div> <p style="font-size: 8px;">Spool Type</p>	<div style="border: 1px solid black; padding: 2px; width: 30px; margin: 0 auto;">E02</div> <p style="font-size: 8px;">Spool Type</p>	<div style="border: 1px solid black; padding: 2px; width: 30px; margin: 0 auto;"></div> <p style="font-size: 8px;">Pressure Range</p>	<div style="border: 1px solid black; padding: 2px; width: 30px; margin: 0 auto;"></div> <p style="font-size: 8px;">Spool Position</p>	<div style="border: 1px solid black; padding: 2px; width: 30px; margin: 0 auto;">0</div> <p style="font-size: 8px;">Seal</p>	<div style="border: 1px solid black; padding: 2px; width: 30px; margin: 0 auto;"></div> <p style="font-size: 8px;">Solenoid Voltage 12V 2.2A</p>	<div style="border: 1px solid black; padding: 2px; width: 30px; margin: 0 auto;"></div> <p style="font-size: 8px;">Connector</p>	<div style="border: 1px solid black; padding: 2px; width: 30px; margin: 0 auto;">3</div> <p style="font-size: 8px;">Spool / Body Design</p>	<div style="border: 1px solid black; padding: 2px; width: 30px; margin: 0 auto;"></div> <p style="font-size: 8px;">Design Series NOTE: Not required when ordering.</p>
--	---	--	--	--	---	---	--	--	--	---	--

Code	Description
C	25 Bar (363 PSI)
D	45 Bar (653 PSI)

Code	Style
C	
E	
K	

Code	Description
W*	Connector as per DIN 185301-803 without plug
J*	Connector DT04-2P "Deutsch"

\* Please order plugs separately.  
See Accessories.

Code	Description
N	Nitrile
V	Fluorocarbon

Weight: Offboard  
D1FV 2.2 kg (4.9 lbs.)



**D1FV Onboard Electronics**

<div style="border: 1px solid black; padding: 2px; width: 30px; margin: 0 auto;">D</div> <p style="font-size: 8px;">Proportional Pressure Reducing Valve</p>	<div style="border: 1px solid black; padding: 2px; width: 30px; margin: 0 auto;">1</div> <p style="font-size: 8px;">Size DIN NG6 CETOP 3 NFPA D03</p>	<div style="border: 1px solid black; padding: 2px; width: 30px; margin: 0 auto;">F</div> <p style="font-size: 8px;">Proportional Control</p>	<div style="border: 1px solid black; padding: 2px; width: 30px; margin: 0 auto;">V</div> <p style="font-size: 8px;">Spool Type</p>	<div style="border: 1px solid black; padding: 2px; width: 30px; margin: 0 auto;">E02</div> <p style="font-size: 8px;">Spool Type</p>	<div style="border: 1px solid black; padding: 2px; width: 30px; margin: 0 auto;"></div> <p style="font-size: 8px;">Pressure Range</p>	<div style="border: 1px solid black; padding: 2px; width: 30px; margin: 0 auto;"></div> <p style="font-size: 8px;">Spool Position</p>	<div style="border: 1px solid black; padding: 2px; width: 30px; margin: 0 auto;">0</div> <p style="font-size: 8px;">Seal</p>	<div style="border: 1px solid black; padding: 2px; width: 30px; margin: 0 auto;"></div> <p style="font-size: 8px;">Input Signal</p>	<div style="border: 1px solid black; padding: 2px; width: 30px; margin: 0 auto;"></div> <p style="font-size: 8px;">Options</p>	<div style="border: 1px solid black; padding: 2px; width: 30px; margin: 0 auto;">3</div> <p style="font-size: 8px;">Spool / Body Design</p>	<div style="border: 1px solid black; padding: 2px; width: 30px; margin: 0 auto;"></div> <p style="font-size: 8px;">Design Series NOTE: Not required when ordering.</p>
--	---	--	--	--	---	---	--	---	--	---	--

Code	Description
C	25 Bar (363 PSI)
D	45 Bar (653 PSI)

Code	Style
C	
E	
K	

Code	Description
N	Nitrile
V	Fluorocarbon

Code	Input Signal <sup>1)</sup>	Function	Port	Options
F0	0...+/-10V	0...+10V > P-A	6 + PE	Potentiometer supply
G0	0...+/-20mA	0...+20mA > P-A	6 + PE	—
M0	0...+/-10V	0...+10V > P-B	6 + PE	Potentiometer supply
S0	4...20mA	12...20mA > P-A	6 + PE	—
W5 <sup>2)</sup>	0...+/-10V 4...20mA 0...+/-20mA	0...+10V > P-A 12...20mA > P-A 0... 20mA > P-A	11 + PE	Potentiometer supply & command preset channel

<sup>1)</sup> Single solenoid always 0...+/-10V respectively 4...20mA.  
<sup>2)</sup> Factory set ± 10V on delivery.

**Bolt Kit:**  
 BK209 (4) 10-24x1.25  
 BK375 (4) M5x30  
**Weight: Onboard**  
 D1FV 2.9 kg (6.4 lbs.)

Please order plugs separately. See Accessories.

Parametrizing cable OBE => RS-232  
 Item no. 40982923

**B**

General	
Design	Direct operated proportional pressure reducing valve
Actuation	Proportional solenoid
Size	NG6 / CETOP 3 / NFPA D03
Mounting Interface	DIN 24340 / ISO 4401 / CETOP RP121 / NFPA
Mounting Position	Unrestricted
Ambient Temperature [°C]	-20...+40; (-4°F...+104°F)
MTTF <sub>D</sub> Value [years]	150 (75)
Vibration Resistance [g]	10 Sinus 5...2000 Hz acc. IEC 68-2-6 30 Random noise 20...2000 Hz acc. IEC 68-2-36 15 Shock acc. IEC 68-2-27
Hydraulic	
Maximum Operating Pressure	Ports P, A, B 350 Bar (5075 PSI) Port T 185 Bar (2683 PSI)
Maximum Pressure Drop PABT / PBAT	350 Bar (5075 PSI)
Fluid	Hydraulic oil as per DIN 51524...51535, other on request
Fluid Temperature [°C]	-20...+40 (-4°F...+104°F)
Viscosity Permitted [cSt] / [mm <sup>2</sup> /s]	20...380 (93...1761 SSU)
Viscosity Recommended [cSt] / [mm <sup>2</sup> /s]	30...80 (139...371 SSU)
Filtration	ISO 4406 (1999) 18/16/13 (acc. NAS 1638: 7)
Maximum Flow	10 LPM (2.6 GPM)
Minimum Primary Pressure	30 Bar (435 PSI)
Static / Dynamic	
Hysteresis [%]	<4
Temperature Drift Solenoid Current [%/K]	<0.02
Electrical	
Duty Ratio [%]	100 ED; CAUTION: Coil temperature up to 150°C (302°F) possible
Protection Class	Standard (as per EN175301-803) IP65 in accordance with EN60529 (with correctly mounted plug-in connector); DT04-2P "Deutsch" IP69K (with correctly mounted plug-in connector)
Supply Voltage [V]	12
Current Consumption [A]	2.2
Resistance [Ohm]	4.4
Coil Insulation Class	F (155 °C) (311°F)
Solenoid Connection	Connector as per EN 175301-803 (code W), DT04-2P "Deutsch" connector (code J). Solenoid identification as per ISO 9461.
Wiring Minimum [mm <sup>2</sup> ]	3x1.5 (AWG 16) overall braid shield (Code W), "Deutsch" connector DP4 2-Pin (Code J)
Wiring Length Maximum [m]	50 (164 ft.) recommended

With electrical connections the protective conductor (PE ⚡) must be connected according to the relevant regulations.

**Electrical Specifications**

Electrical		
Duty Ratio	[%]	100 ED; CAUTION: Coil temperature up to 150°C (302°F) possible
Protection Class		IP65 in accordance with EN 60529 (plugged and mounted)
Supply Voltage/ripple DC	[V]	18...30, ripple < 5% eff., surge free
Current Consumption Maximum	[A]	2.0
Pre-fusing Medium Lag	[A]	2.5
Input Signal		
Codes F0 & W5 Voltage	[V]	+10...0...-10, ripple < 0.01 % eff., surge free, Ri = 100kOhm, 0...+10V => P -> A
Code M0 Voltage	[V]	+10...0...-10, ripple < 0.01 % eff., surge free, Ri = 100kOhm, 0...+10V => P -> B
Codes S0 & W5 Current	[mA]	4...12...20, ripple < 0.01 % eff., surge free, Ri = 200Ohm, 12...20mA => P -> A < 3.6 mA = enable off, > 3.8 mA = enable on (acc. to NAMUR NE43)
Code G0	[mA]	+20...0...-20, ripple < 0.01 % eff., surge free, Ri = 200Ohm, 0...+20mA => P -> A
Differential input max.		
Codes F0, G0, M0 & S0	[V]	30 for terminal D and E against PE (terminal G) 11 for terminal D and E against 0V (terminal B)
Code W5	[V]	30 for terminal 4 and 5 against PE (terminal PE) 11 for terminal 4 and 5 against 0V (terminal 2)
Channel Recall Signal	[V]	0...2.5: off / 5...30: on / Ri = 100 kOhm
Adjustment Ranges:		
Min	[%]	0...50
Max	[%]	50...100
Ramp	[s]	0...32.5
Interface		RS-232, parametrizing connection 5 pole
EMC		EN 61000-6-2, EN 61000-6-4
Central Connection		
Codes F0, G0 M0 & S0		6 + PE acc. to EN 175201-804
Code W5		11 + PE acc. to EN 175201-804
Wiring Minimum		
Codes F0, G0 M0 & S0	[mm <sup>2</sup> ]	7 x 1.0 (AWG16) overall braid shield
Code W5	[mm <sup>2</sup> ]	11 x 1.0 (AWG16) overall braid shield
Wiring Length Maximum	[m]	50 (164 ft.)

**B**

**Performance Curves**

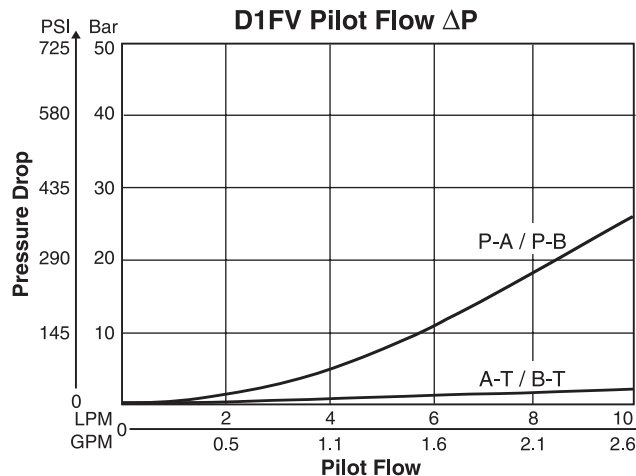

All performance curves measured with HLP46 at 50°C (122°F).

D1FV.indd, ddp



**Code F0, M0**  
**6 + PE acc. to EN 175201-804**

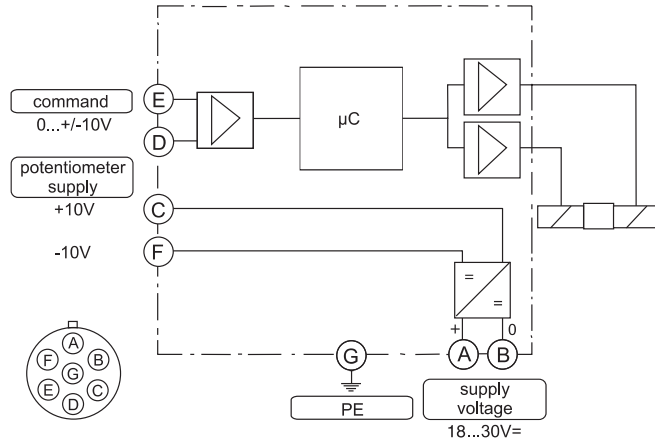

**Code G0, S0**  
**6 + PE acc. to EN 175201-804**

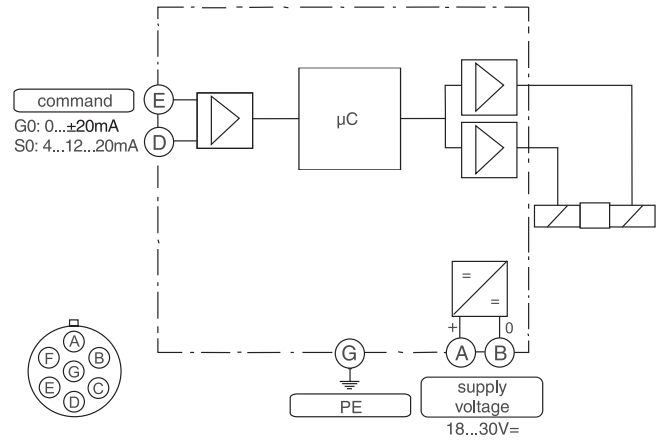

**Code W5**  
**11 + PE acc. to EN 175201-804**

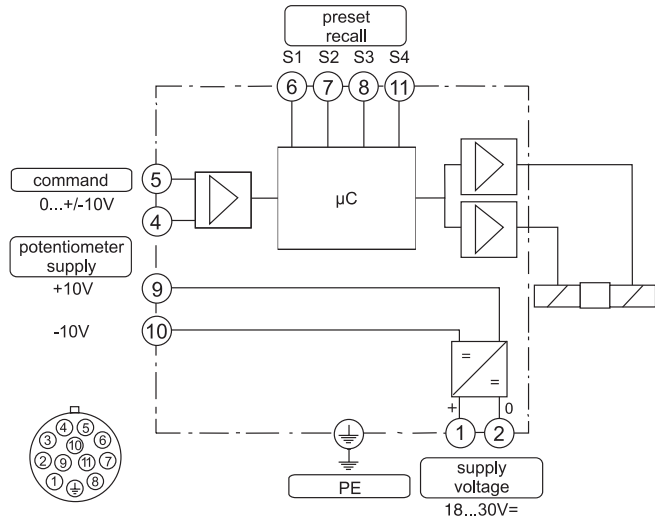

**B**

**ProPxD Interface Program**

The ProPxD software allows quick and easy setting of the digital valve electronics. Individual parameters as well as complete settings can be viewed, changed and saved via the comfortable user interface. Parameter sets saved in the non-volatile memory can be loaded to other valves of the same type or printed out for documentation purposes.

**Features**

- Simple editing of all parameters.
- Storage and loading of optimized parameter adjustments.
- Executable with all Windows® operating systems from Windows® 95 upwards.
- Communication between PC and electronics via serial interface RS-232.

The valve electronics cannot be connected to a PC with a standard USB cable – this can result in damages of PC and/or valve electronics.

Simple to use interface program. Download free of charge [www.parker.com/euro\\_hcd](http://www.parker.com/euro_hcd) → **Services** → **downloads**

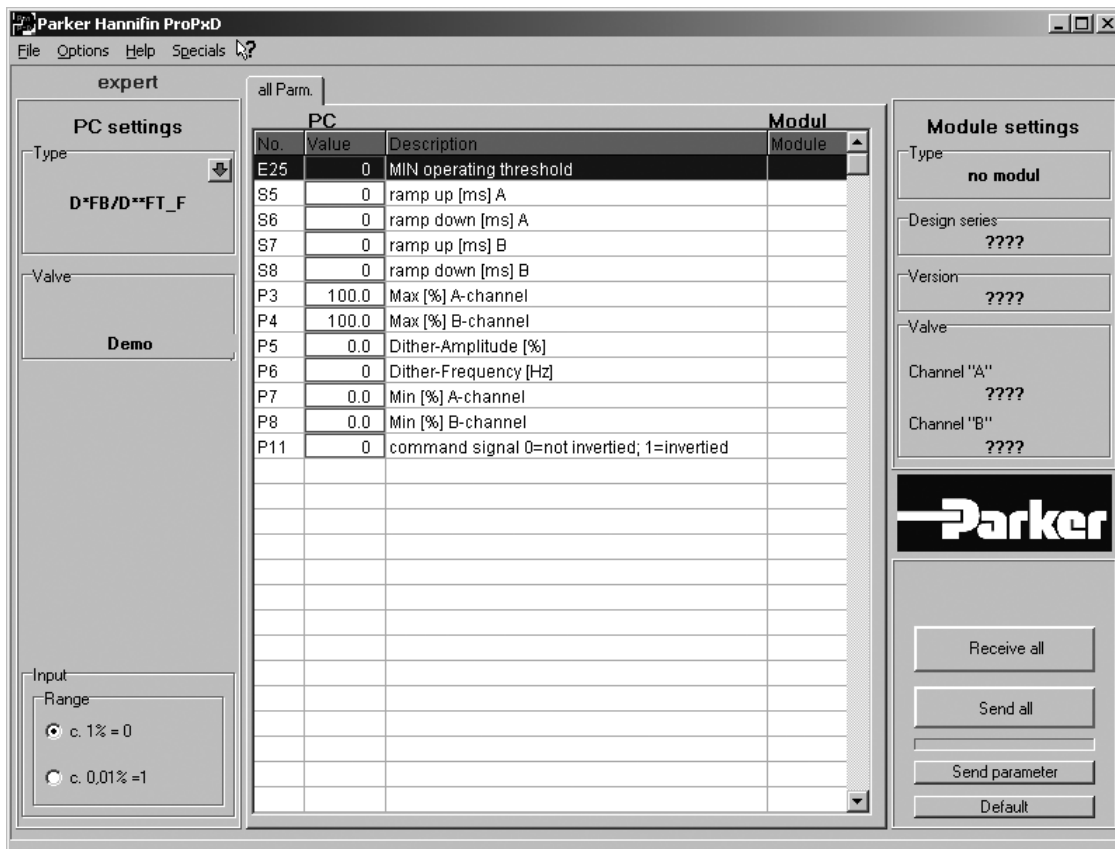

The parametrizing cable may be ordered under item no. 40982923.

Inch equivalents for millimeter dimensions are shown in (\*\*)

**D1FV\*C**

with DT04-2P  
"Deutsch" Connector



**B**

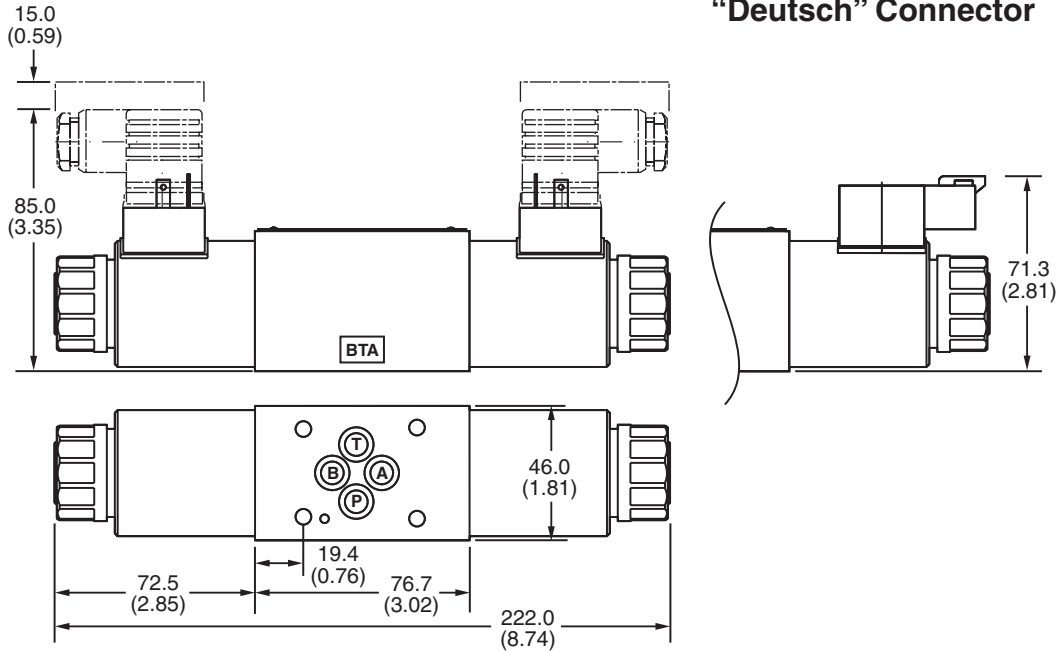

**D1FV\*E**

**D1FV\*K**

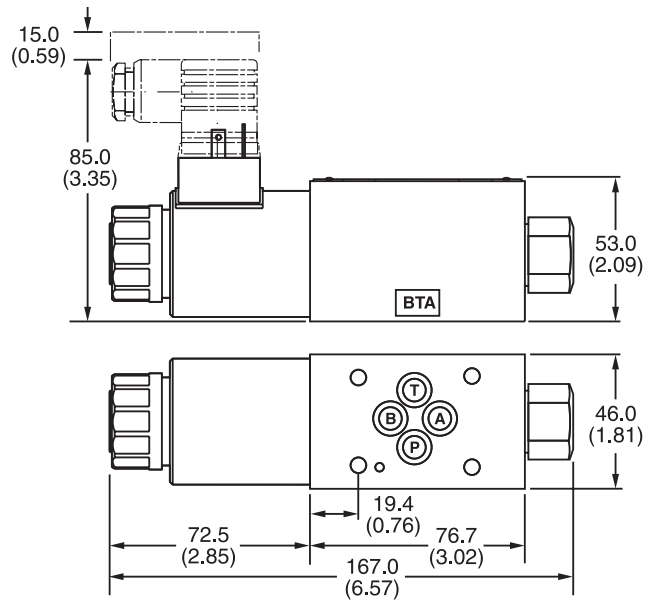
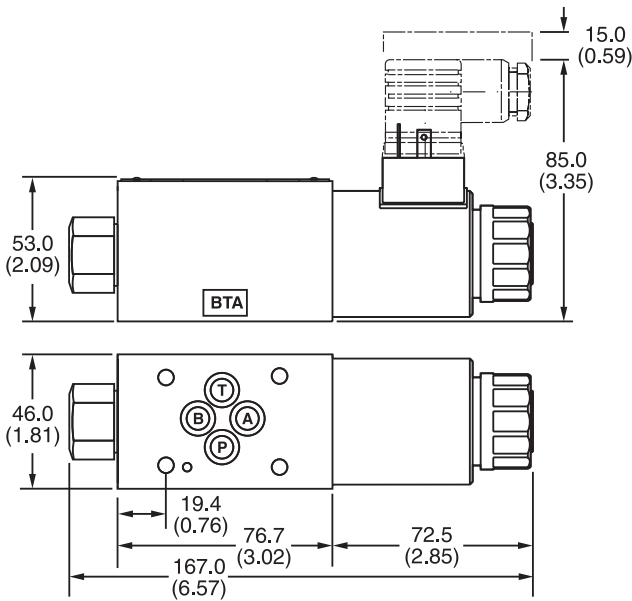

Surface Finish	Kit			Seal Kit
	BK375	4x M5x30 DIN 912 12.9	7.6 Nm (5.6 lb.-ft.) ±15 %	Nitrile: SK-D1FB-N Fluorocarbon: SK-D1FBV

**Dimensions**

**Proportional Pressure Reducing Valves  
Series D1FV (Onboard Electronics)**

Inch equivalents for millimeter dimensions are shown in (\*\*)

**D1FV\*C OBE**

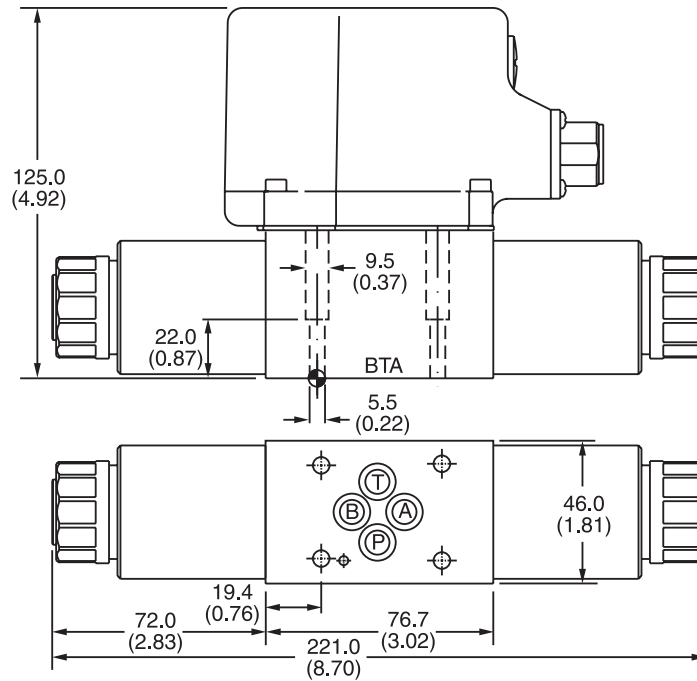

**B**

**D1FV\*E OBE**

**D1FV\*K OBE**

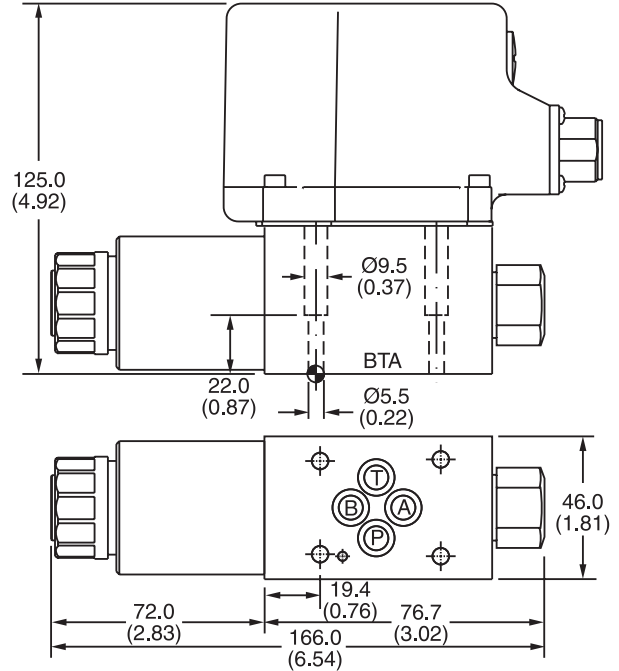
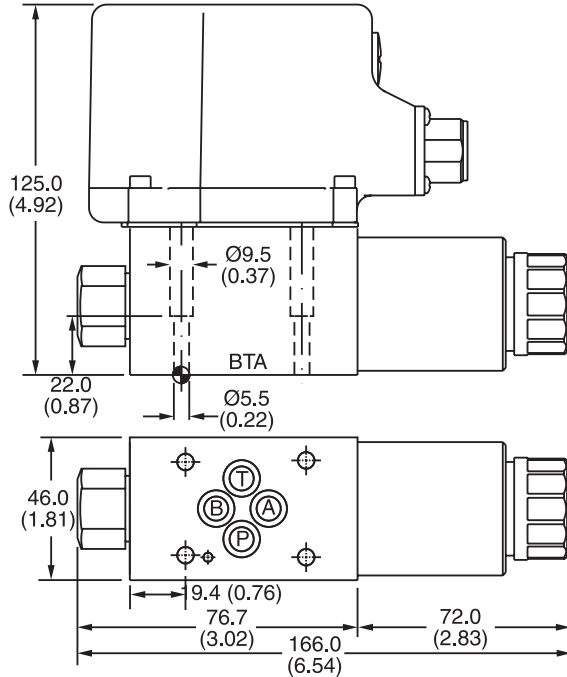

Surface Finish	Kit	Kit	Kit	Seal Kit
	BK375	4x M5x30 DIN 912 12.9	7.6 Nm (5.6 lb.-ft.) ±15 %	Nitrile: SK-D1FB-N Fluorocarbon: SK-D1FBV