

GVI

GLOBAL VEHICLE INVERTER

Mobile Inverters for Traction, Electro-Hydraulic Pumps (EHP)
and Auxiliary Systems 24 to 650 VDC





WARNING – USER RESPONSIBILITY

FAILURE OR IMPROPER SELECTION OR IMPROPER USE OF THE PRODUCTS DESCRIBED HEREIN OR RELATED ITEMS CAN CAUSE DEATH, PERSONAL INJURY AND PROPERTY DAMAGE.

- This document and other information from Parker-Hannifin Corporation, its subsidiaries and authorized distributors provide product or system options for further investigation by users having technical expertise.
- The user, through its own analysis and testing, is solely responsible for making the final selection of the system and components and assuring that all performance, endurance, maintenance, safety and warning requirements of the application are met. The user must analyze all aspects of the application, follow applicable industry standards, and follow the information concerning the product in the current product catalog and in any other materials provided from Parker or its subsidiaries or authorized distributors.
- To the extent that Parker or its subsidiaries or authorized distributors provide component or system options based upon data or specifications provided by the user, the user is responsible for determining that such data and specifications are suitable and sufficient for all applications and reasonably foreseeable uses of the components or systems.

Inverters for Traction, Electro-Hydraulic Pumps (EHP) and Auxiliary Systems

Low Voltage Mobile Inverters - GVI



- Overview 5
- Product Details 6
- Technical Data 6
- Dimensions 7
- Order Code..... 8

High Voltage Mobile Inverters - GVI



- Overview 9
- Product Details10
- Technical Data10
- Dimensions11
- Order Code.....12

GVI Configuration Tool

- Description13
- Configuration Tool Features13

Related Products

- Global Vehicle Motor (GVM).....14
- Electro-Hydraulic Pumps (EHP).....14

Low Voltage Mobile Inverters - GVI

Overview

The Low Voltage Parker GVI series represents the latest design standards for compact and reliable inverters for mobile applications. Providing a motor control solution for low voltage battery systems between 24 and 96VDC, GVI motor controllers offer OEMs a superb combination of power, performance and functionality. The compact dimensions and high efficiency of GVI controllers make integration into very limited spaces a reality without sacrificing output performance. Partnered with the Parker GVM range of highly efficient PMAC mobile motors, the GVI range aims to provide the lowest possible installed cost, whilst still maintaining superior reliability even in the most demanding of applications.

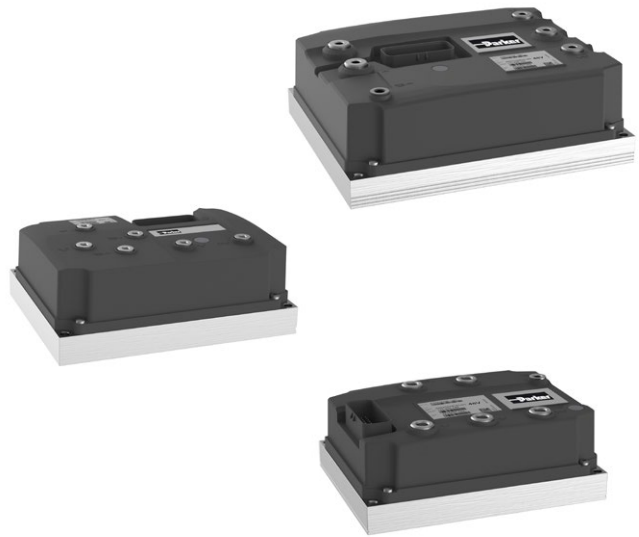

Product Features

- High efficiency cold plate design
- IP65 protection class
- Motor temperature sensor input
- Sin/Cos encoder feedback
- CAN J1939 or CANopen communication
- Parker IQAN compatible
- Configurable coil drive digital outputs
- 2 Analog inputs / 9 Digital inputs / 6 Digital outputs for use with I/O control mode

Applications

On and off highway vehicles:

- Light and medium duty traction
- Electrohydraulic pump control
- Electric air conditioning compressors
- Electric air brake compressors

Technical characteristics - overview

Model	GVI
Motor type	Permanent magnet AC
Nominal voltage	24 / 48 / 80 / 96 Vdc
Peak current	700 Arms
Peak power	82 kVA
Switching frequency	4, 8, 12, 16 kHz
Operating temperature range	-40°C to +55°C
Storage temperature range	-40°C to +70°C
Protection	IP65
Control type	Speed, Current, Torque and DC level Control
Feedback	Sin/Cos encoder
Communications	CAN J1939, CANopen
Cooling	Cold plate
Conformance	IEC60068, EN61000-4, EN1175-1, IEC60529, EN55022
Output frequency	0 - 599 Hz ¹⁾

¹⁾ For output frequencies > 599 Hz please contact Parker

Product Details

Thanks to an IP65 protection class, the drive can be direct vehicle mounted without an enclosure.
(no direct high pressure spray)

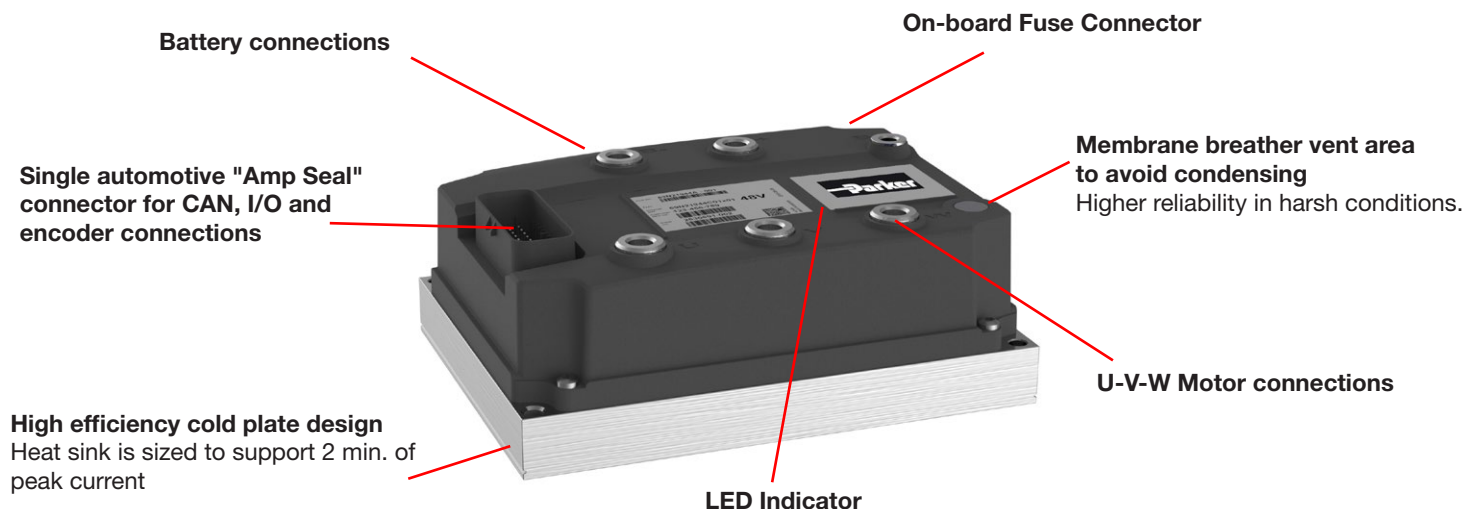

Technical Data

Product Code	Frame Size	Output Current [Arms] S2, 2 min ⁽¹⁾	Output Current [Arms] S2, 1 h ⁽²⁾	Nominal input voltage [Vdc]	Battery Voltage Range [Vdc]	Weight [Kg] (lbs)
GVI-C024-0350S1-S00-G0000	C	350	150	24	16-27	2.3 (5)
GVI-C048-0280S1-S00-G0000	C	280	120	48	33-53	2.3 (5)
GVI-D024-0550S1-S00-G0000	D	550	275	24	16-27	2.5 (5.5)
GVI-D048-0450S1-S00-G0000	D	450	225	48	33-53	2.5 (5.5)
GVI-D048-0550S1-S00-G0000	D	550	275	48	33-53	2.5 (5.5)
GVI-D080-0230S1-S00-G0000	D	230	115	80	50-88	2.5 (5.5)
GVI-D080-0350S1-S00-G0000	D	350	175	80	50-88	2.5 (5.5)
GVI-D080-0400S1-S00-G0000	D	400	200	80	50-88	2.5 (5.5)
GVI-D096-0230S1-S00-G0000	D	230	115	96	56-106	2.5 (5.5)
GVI-D096-0350S1-S00-G0000	D	350	175	96	56-106	2.5 (5.5)
GVI-D096-0400S1-S00-G0000	D	400	180	96	56-106	2.5 (5.5)
GVI-E048-0700S1-S00-G0000	E	700	350	48	33-53	4.8 (10.6)
GVI-E080-0500S1-S00-G0000	E	500	250	80	50-88	4.8 (10.6)
GVI-E080-0700S1-S00-G0000	E	700	350	80	50-88	4.8 (10.6)
GVI-E096-0500S1-S00-G0000	E	500	250	96	56-106	4.8 (10.6)
GVI-E096-0700S1-S00-G0000	E	700	350	96	56-106	4.8 (10.6)

Notes: All current ratings are rms values per motor phase.

(1) 2 minute rating at 8kHz switching frequency and 25°C ambient temperature

(2) 1 hr rating at 8kHz switching frequency and 40°C ambient temperature

Dimensions

Frame C

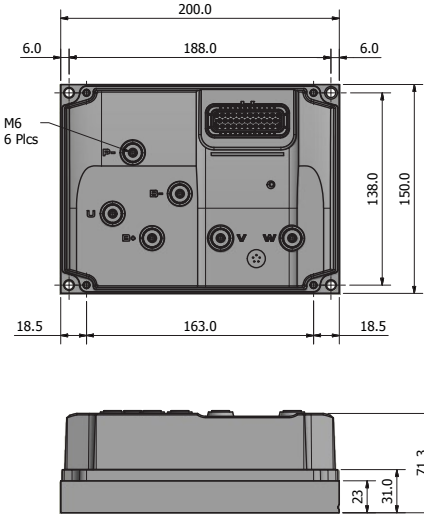

Dimensions [mm]

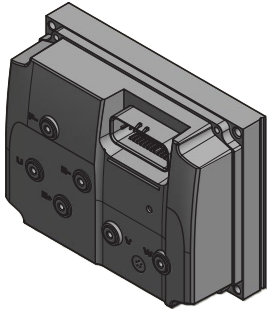

Frame D

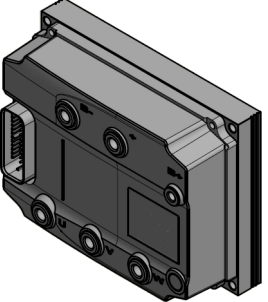
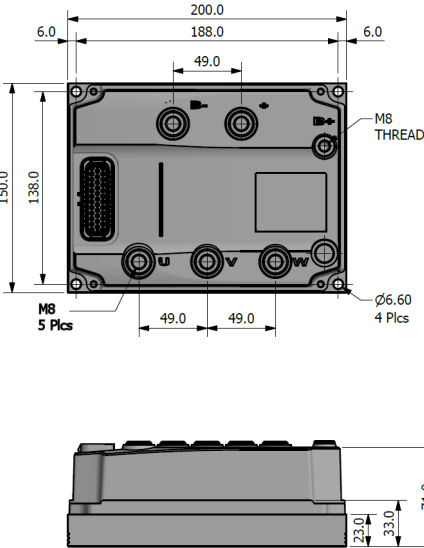

Frame E

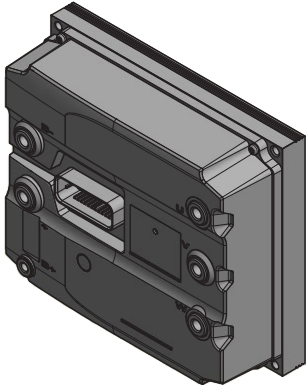
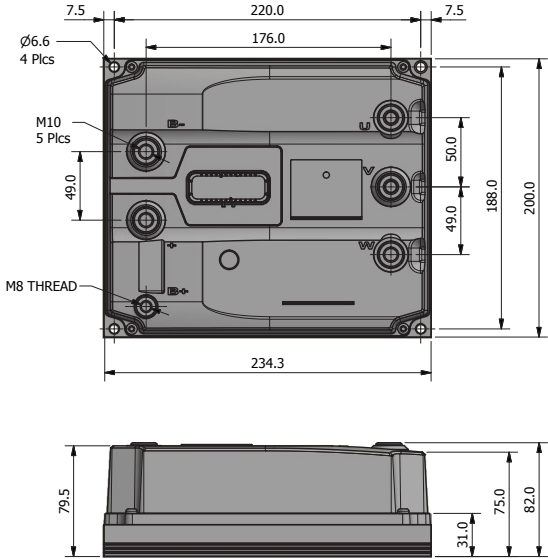

Order Code

	1		2	3		4	5	6		7	8		9
Order example	GVI	-	C	024	-	0350	S	1	-	S	00	-	G0000

1	Inverter family
GVI	Global Vehicle Inverter
2	Frame size
C	Frame size C
D	Frame size D
E	Frame size E
3	Nominal DC Supply
024	24 VDC
048	48 VDC
080	80 VDC
096	96 VDC
4	Current Rating
24 VDC Nominal Voltage	
0350	350 A - Frame C
0550	550 A - Frame D
48 VDC Nominal Voltage	
0280	280 A - Frame C
0450	450 A - Frame D
0550	550 A - Frame D
0700	700 A - Frame E
80 VDC Nominal Voltage	
0230	230 A - Frame D
0350	350 A - Frame D
0400	400 A - Frame D
0500	500 A - Frame E
0700	700 A - Frame E
96 VDC Nominal Voltage	
0230	230 A - Frame D
0350	350 A - Frame D
0400	400 A - Frame D
0500	500 A - Frame E
0700	700 A - Frame E
5	Package
S	Single
6	Series
1	Series 1
7	Feedback Type
S	Sin/Cos encoder
8	Reserved
00	
9	Special Option
G0000	Global specification*
N0000	North America specification
E0000	European specification

* G0000 Global specification is the default reference. For other specifications please contact Parker

High Voltage Mobile Inverters - GVI

Overview

Description

Providing a motor control solution for battery systems up to 650 V, high voltage GVI controllers offer OEMs high reliability and minimized total lifetime cost. The rugged IP6K9K design is perfect for the harsh environments of mobile equipment, while the integrated DC filter and wide operating voltage range allow maximum flexibility in system design.

Partnered with the Parker GVM range of highly efficient PMAC mobile motors, the GVI range aims to provide the lowest possible installed cost, highest efficiency while still maintaining superior reliability even in the most demanding of applications.



Product Features

- Auto-tuning
- Liquid cooled design
- IP6K9K protection class
- Motor temperature input
- Resolver feedback
- CAN J1939 or CANopen communication
- Parker IQAN compatible
- 4 Digital inputs* and 1 digital output
- Full current available at 100-750 VDC
- Motor Torque Off and HVIL

Applications

On and off highway vehicles:

- Off highway traction
- Electrohydraulic pump control
- Electric air conditioning compressors
- Electric air brake compressors
- Agricultural implements

Technical characteristics - Overview

Model	GVI
Motor type	Permanent magnet AC
Nominal voltage	650 Vdc
Peak current	500 Arms
Peak power	300 kVA
Switching frequency	1, 2, 4, 6 kHz
Operating temperature range	-40°C to +85°C
Storage temperature range	-40°C to +85°C
Protection	IP6K9K
Control type	Speed, Current, Torque and DC level Control
Feedback	Resolver
Communications	CAN J1939, CANopen
Cooling	WEG liquid cooled
Conformance	ISO20653:2006, ISO16750-4, ISO16750-3 EN60068-2, CISPR25 Ed.4 Class 3, ISO11452-4, ISO11452-8, ISO7637-2
Output frequency	0 - 599 Hz ¹⁾

¹⁾ For output frequencies > 599Hz please contact Parker

²⁾ For internal only HVIL option please contact Parker

*Standard firmware reserves 2 Digital inputs for CAN address ID

Product Details

Rugged IP6K9K design suitable for the demanding environment of electric vehicles

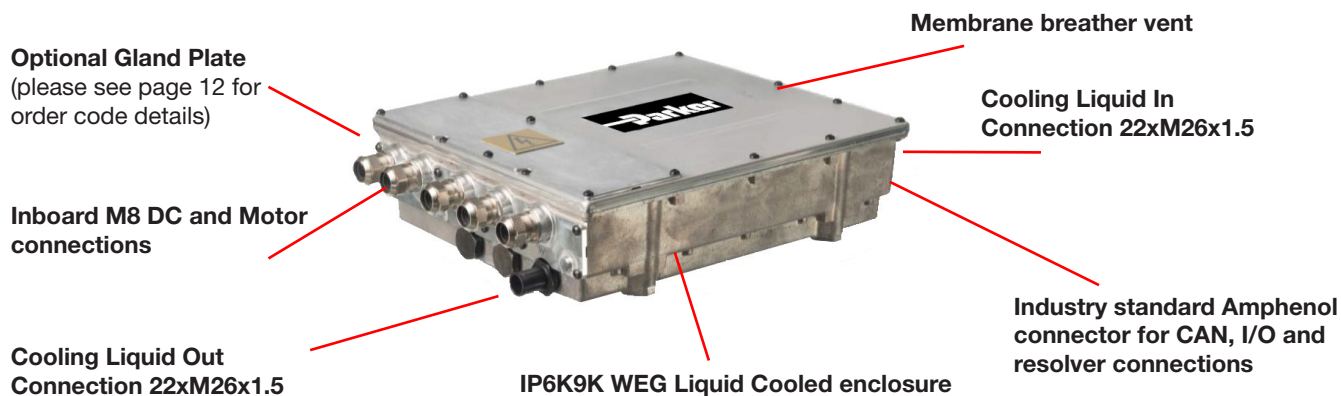

Technical Data

Product Code	Frame Size	Output Current [Arms] S2, 10 s ⁽¹⁾	Output Current [Arms] S2, 1 h ⁽²⁾	Nominal input voltage [Vdc]	Battery Voltage Range [Vdc]	Weight [Kg] (lbs)
GVI-G650-0300S1-R00-G0000	G	320	225	650	100-750	21 (46.3)
GVI-H650-0500S1-R00-G0000	H	500	375	650	100-750	25 (55.1)

Notes: All current ratings are rms values per motor phase.

(1) 60 second rating at 4kHz switching frequency and 25°C

(2) 1 hr rating at 4kHz switching frequency and 60°C coolant temperature, 85°C ambient and 18l/min flow

Minimum Coolant Flows: @Coolant temp <0°C >5 l/min
 @Coolant temp 0-50°C >10-15 l/min
 @Coolant temp >50°C >15-20 l/min

Dimensions

Frame G

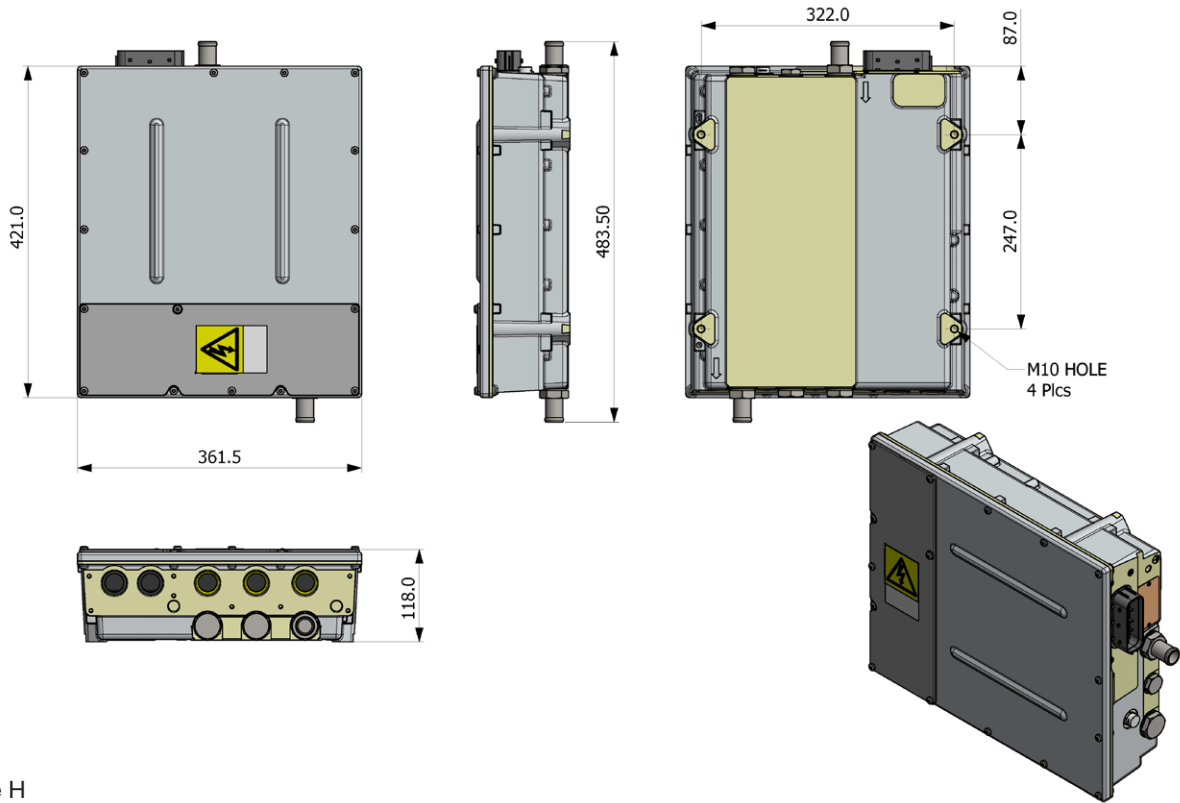

Frame H

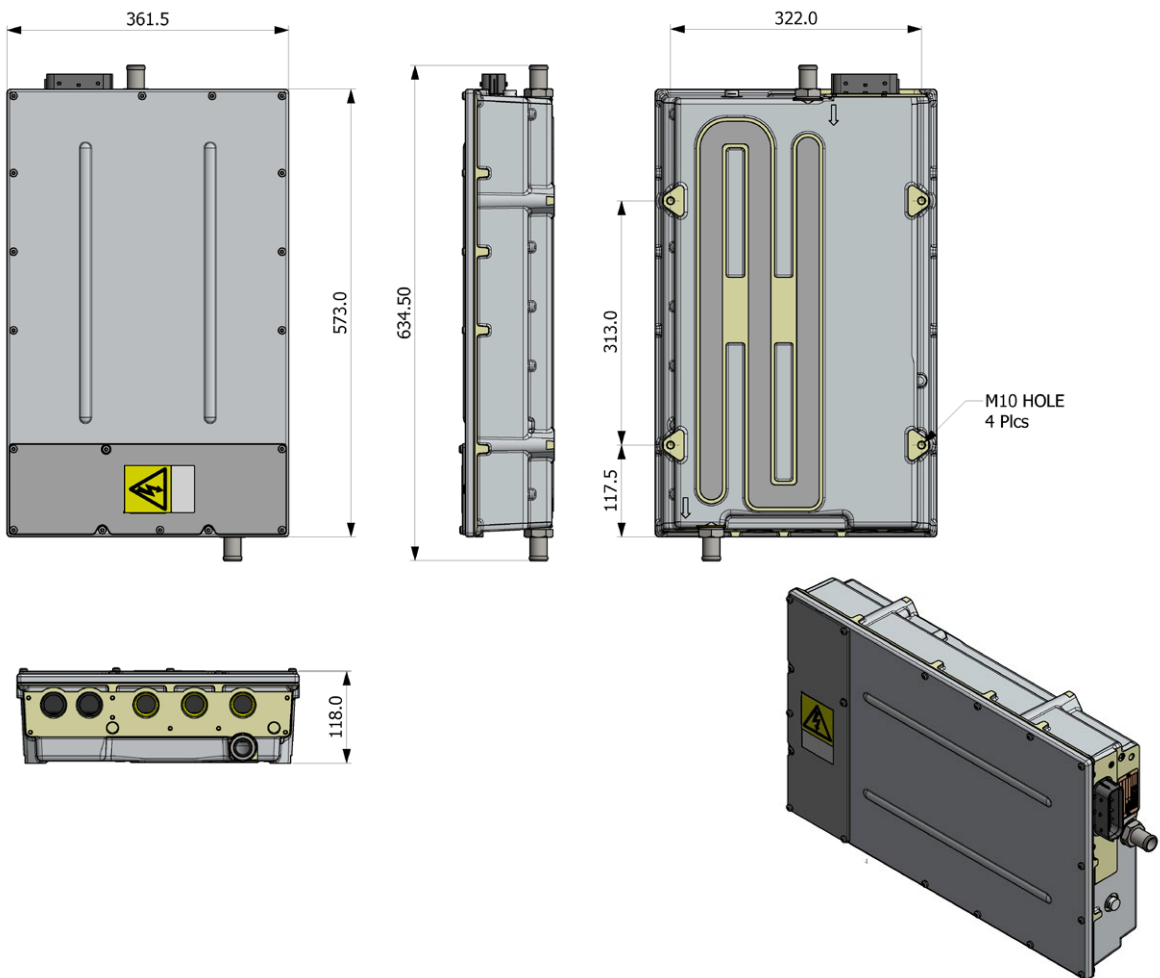

Order Code

	1		2	3		4	5	6		7	8		9
Order example	GVI	-	H	650	-	0500	S	1	-	R	00	-	G0000

1	Drive Family	
	GVI	Global Vehicle Inverter
2	Frame size	
	G	Frame size G
	H	Frame size H
3	Nominal DC Supply	
	650	650 VDC
4	Current Rating	
	650 VDC Nominal Voltage	
	0300	320 A - Frame G
	0500	500 A - Frame H
5	Package	
	S	Single
6	Series	
	1	Series 1
7	Feedback type	
	R	Resolver
8	Reserved	
	00	
9	Special Option	
	G0000	Global Specification*
	N0000	North American Specification
	E0000	European Specification

* G0000 Global specification is the default reference. For other specifications please contact Parker

Order Code	Description
GVI-GH-ADAPTORKIT	Power Connection Gland Plate Adaptor Kit (Frames G-H Only)

GVI Configuration Tool

Description

The Parker GVI configuration tool provides everything required to configure, tune and commission the GVI inverter. Using one of a range of popular USB-CAN adaptors, the GVI configuration tool may be used on any Windows based PC. Simple and intuitive, the tool allows for cloning, firmware updates and tuning of the full range of possible GVI/GVM combinations. The Parker GVI configuration tool also provides a powerful graphing utility and a CANopen master facility aids commissioning by remotely controlling the GVI directly.

To download the tool for free and view video tutorials please visit the GVI product page on Parker.com.

Configuration Tool Features

- Project based configuration tool
- Clone facility for rapid programming
- Firmware update wizard
- Customisable parameter group displays
- NMT control to start/stop the GVI application
- Online and Offline operation modes
- Online graphing tool for up to 8 parameters
- Fast transient 4 channel oscilloscope
- CANopen master simulation

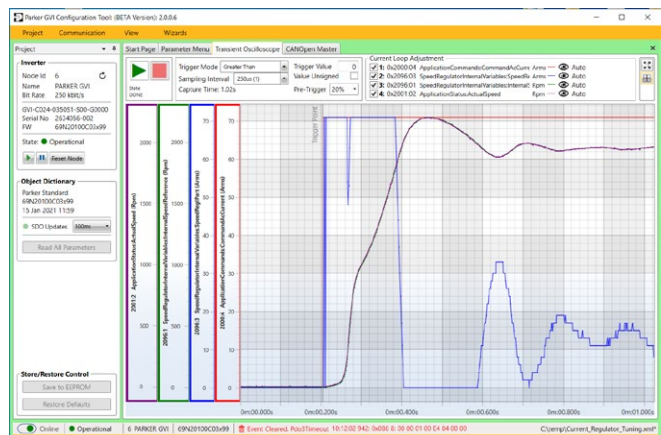
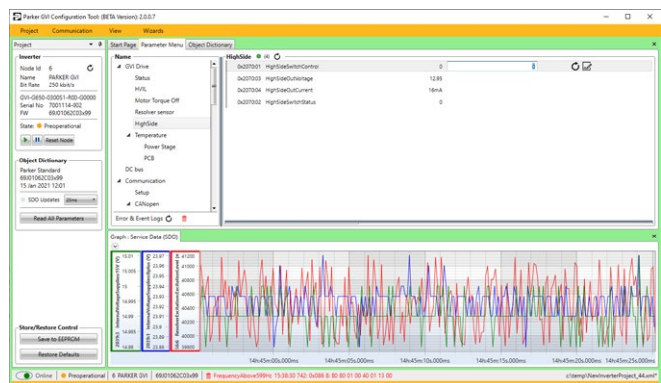
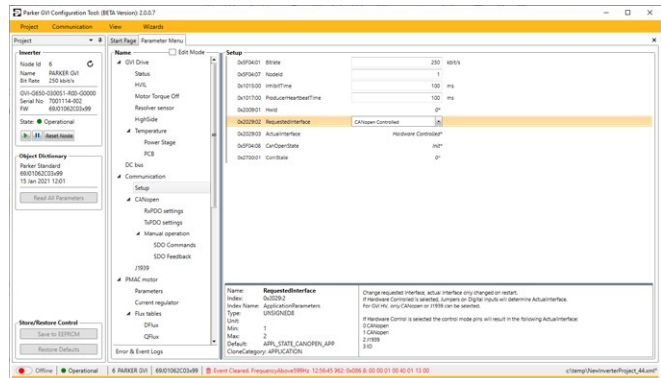

Related Products

Global Vehicle Motor (GVM)

Description

PMAC servomotors offer the best solution to meet the requirements of vehicle duty performance. The torque density and speed capabilities of Parker Permanent Magnet AC motors (PMAC) provide the speed and torque required to achieve breakthrough performance in a variety of vehicle platforms.

Product Features

- High efficiency
- Compactness (High power density)
- Can be used either as motor or generator
- Operating voltages available from 24 to 800 VDC

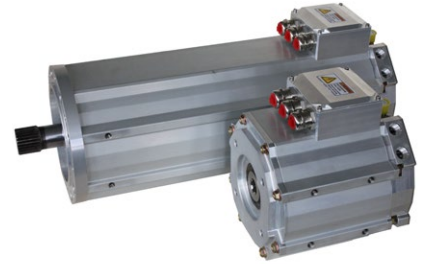

Electro-Hydraulic Pumps (EHP)

Description

The Electro-Hydraulic Pump (EHP) kits are designed for hybrid electric and all electric mobile applications. EHP systems consist of an electric motor directly coupled to an hydraulic pump controlled by a high performance mobile hardened inverter.

Parker's global expertise in hydraulic, electric motor, and drive technologies is brought together in the EHP to create a system that has been optimally adapted to the customer requirements.

Product Features

- Complete Electro-Hydraulic Pump solutions
- Pre engineered system with fully validated pressure, flow and voltage data
- Wide range of motor/pump combinations to adapt to every battery pack





Parker's Motion & Control Technologies

At Parker, we're guided by a relentless drive to help our customers become more productive and achieve higher levels of profitability by engineering the best systems for their requirements. It means looking at customer applications from many angles to find new ways to create value. Whatever the motion and control technology need, Parker has the experience, breadth of product and global reach to consistently deliver. No company knows more about motion and control technology than Parker. For further info call 00800 27 27 5374



Aerospace Key Markets

- Aftermarket services
- Commercial transports
- Engines
- General & business aviation
- Helicopters
- Launch vehicles
- Military aircraft
- Missiles
- Power generation
- Regional transports
- Unmanned aerial vehicles

Key Products

- Control systems & actuation products
- Engine systems & components
- Fluid conveyance systems & components
- Fluid metering, delivery & atomization devices
- Fuel systems & components
- Fuel tank inerting systems
- Hydraulic systems & components
- Thermal management
- Wheels & brakes



Climate Control Key Markets

- Agriculture
- Air conditioning
- Construction Machinery
- Food & beverage
- Industrial machinery
- Life sciences
- Oil & gas
- Precision cooling
- Process
- Refrigeration
- Transportation

Key Products

- Accumulators
- Advanced actuators
- CO₂ controls
- Electronic controllers
- Filter driers
- Hand shut-off valves
- Heat exchangers
- Hose & fittings
- Pressure regulating valves
- Refrigerant distributors
- Safety relief valves
- Smart pumps
- Solenoid valves
- Thermostatic expansion valves



Electromechanical Key Markets

- Aerospace
- Factory automation
- Life science & medical
- Machine tools
- Packaging machinery
- Paper machinery
- Plastics machinery & converting
- Primary metals
- Semiconductor & electronics
- Textile
- Wire & cable

Key Products

- AC/DC drives & systems
- Electric actuators, gantry robots & slides
- Electrohydraulic actuation systems
- Electromechanical actuation systems
- Human machine interface
- Linear motors
- Stepper motors, servo motors, drives & controls
- Structural extrusions



Filtration Key Markets

- Aerospace
- Food & beverage
- Industrial plant & equipment
- Life sciences
- Marine
- Mobile equipment
- Oil & gas
- Power generation & renewable energy
- Process
- Transportation
- Water Purification

Key Products

- Analytical gas generators
- Compressed air filters & dryers
- Engine air, coolant, fuel & oil filtration systems
- Fluid condition monitoring systems
- Hydraulic & lubrication filters
- Hydrogen, nitrogen & zero air generators
- Instrumentation filters
- Membrane & fiber filters
- Microfiltration
- Sterile air filtration
- Water desalination & purification filters & systems



Fluid & Gas Handling

Key Markets

- Aerial lift
- Agriculture
- Bulk chemical handling
- Construction machinery
- Food & beverage
- Fuel & gas delivery
- Industrial machinery
- Life sciences
- Marine
- Mining
- Mobile
- Oil & gas
- Renewable energy
- Transportation

Key Products

- Check valves
- Connectors for low pressure fluid conveyance
- Deep sea umbilicals
- Diagnostic equipment
- Hose couplings
- Industrial hose
- Mooring systems & power cables
- PTFE hose & tubing
- Quick couplings
- Rubber & thermoplastic hose
- Tube fittings & adapters
- Tubing & plastic fittings



Hydraulics

Key Markets

- Aerial lift
- Agriculture
- Alternative energy
- Construction machinery
- Forestry
- Industrial machinery
- Machine tools
- Marine
- Material handling
- Mining
- Oil & gas
- Power generation
- Refuse vehicles
- Renewable energy
- Truck hydraulics
- Turf equipment

Key Products

- Accumulators
- Cartridge valves
- Electrohydraulic actuators
- Human machine interfaces
- Hybrid drives
- Hydraulic cylinders
- Hydraulic motors & pumps
- Hydraulic systems
- Hydraulic valves & controls
- Hydrostatic steering
- Integrated hydraulic circuits
- Power take-offs
- Power units
- Rotary actuators
- Sensors



Pneumatics

Key Markets

- Aerospace
- Conveyor & material handling
- Factory automation
- Life science & medical
- Machine tools
- Packaging machinery
- Transportation & automotive

Key Products

- Air preparation
- Brass fittings & valves
- Manifolds
- Pneumatic accessories
- Pneumatic actuators & grippers
- Pneumatic valves & controls
- Quick disconnects
- Rotary actuators
- Rubber & thermoplastic hose & couplings
- Structural extrusions
- Thermoplastic tubing & fittings
- Vacuum generators, cups & sensors



Process Control

Key Markets

- Alternative fuels
- Biopharmaceuticals
- Chemical & refining
- Food & beverage
- Marine & shipbuilding
- Medical & dental
- Microelectronics
- Nuclear Power
- Offshore oil exploration
- Oil & gas
- Pharmaceuticals
- Power generation
- Pulp & paper
- Steel
- Water/wastewater

Key Products

- Analytical Instruments
- Analytical sample conditioning products & systems
- Chemical injection fittings & valves
- Fluoropolymer chemical delivery fittings, valves & pumps
- High purity gas delivery fittings, valves, regulators & digital flow controllers
- Industrial mass flow meters/ controllers
- Permanent no-weld tube fittings
- Precision industrial regulators & flow controllers
- Process control double block & bleeds
- Process control fittings, valves, regulators & manifold valves



Sealing & Shielding

Key Markets

- Aerospace
- Chemical processing
- Consumer
- Fluid power
- General industrial
- Information technology
- Life sciences
- Microelectronics
- Military
- Oil & gas
- Power generation
- Renewable energy
- Telecommunications
- Transportation

Key Products

- Dynamic seals
- Elastomeric o-rings
- Electro-medical instrument design & assembly
- EMI shielding
- Extruded & precision-cut, fabricated elastomeric seals
- High temperature metal seals
- Homogeneous & inserted elastomeric shapes
- Medical device fabrication & assembly
- Metal & plastic retained composite seals
- Shielded optical windows
- Silicone tubing & extrusions
- Thermal management
- Vibration dampening

Parker Hannifin Corporation
Motion Systems Group Europe
Parker Hannifin EMEA Sàrl European Headquarters
La Tuilière 6 Etoy
Switzerland CH-1163
www.parker.com

192_300118/UK 05/2024

Your Local Authorized Parker Distributor

© 2024 Parker Hannifin Corporation

